

High Power 0.5 to 1000 MHz



TIA

up to 10W (+40 dBm) output

MODEL NO.	FREQ. (MHz) f_L - f_U	GAIN (dB)		MAXIMUM POWER (dBm)			DYNAMIC RANGE		VSWR		AC POWER			CASE STYLE	ISO 9001 CERTIFIED	PRICE \$ Qty. (1-9)
		Min.	Flatness Max.	Output (1 dB Comp.) Typ.	Min.	Input Max. (no damage)	NF (dB) Typ.	IP3 (dBm) Typ.	In	Out	Volt (note1)	Freq. Hz	VA Max.			
TIA-900-10	100-900	28	±2.5	+42	+40	+25	13	51	2.5:1	2.5:1	110	50/60	475	AP176	—	3,695.00
TIA-1000-4	100-1000	19	±1.5	+39	+36	+25	12	48	2.5:1	2.5:1	110	50/60	400	AP176	—	1,995.00
TIA-1000-1R8	0.50-1000	35	±2.0	+35	+32	+7	8*	45	1.9:1	2.5:1	110	50/60	140	AP175	—	1,495.00

features

- wide bandwidth, 0.5-1000 MHz
- instrument model, with built-in power supply, 110/220V operation
- high power output, (at 3.5 dB compression)
45 dBm typical for TIA-900-10
42 dBm typical for TIA-1000-4
37 dBm typical for TIA-1000-1R8
- high gain,
38 dB typical for TIA-1000-1R8
34 dB typical for TIA-900-10
- high reverse isolation,
80 dB typical for TIA-900-10, TIA-1000-1R8
55 dB typical for TIA-1000-4
- 100% Burn-In at +25°C, 48 hours
- thermally self-protected, led indicator

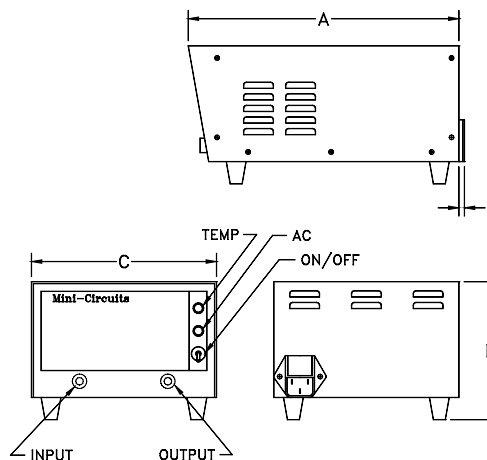

NOTES:

- * NF above 400 MHz. At low frequency, NF increases to 16 dB Typ.
 C. Prices and Specifications subject to change without notice.
 D. For Quality Control Procedures see Table of Contents, Section 0, see "Mini-Circuits Guarantees Quality" article.
- For TIA-1000 models, add dash 2 (-2) to model no. for 220V operation.
 - Gain and maximum output power specified at 25°C±5°C., over temperature, specifications degrade approximately 1dB, gain flatness ±2.5dB maximum for TIA-1000-1R8 and TIA-1000-4.
 - Open load is not recommended, potentially can cause damage. With no load, derate max input power by 20 dB.
 - VSWR specified at:
350-900 MHz for TIA-900-10
350-1000 MHz for TIA-1000-4
340-1000 MHz for TIA-1000-1R8
 - Operating temperature: 0°C to +55°C.
Storage temperature: -40°C to +70°C.
 - All TIA models are protected under U.S. patent 5, 101, 171.

Outline drawing and dimensions

case no.		A	B	C	D	wt. grams	NOTES
AP175	inch mm	9.8 248.9	5.0 127.0	6.7 170.2	0.2 5.1	3500	A10, D7, G1, G2
AP176	inch mm	19.5 495.3	6.0 152.4	12.5 317.5	0.2 5.1	9500	A10, D7, G1, G2

- A10. Case material: aluminum alloy. Finish: grey paint.
 D7. Connectors: BNC only.
 G1. Keep area adjacent to fan and louvers clear to permit air flow to pass. Caution: Do not insert anything especially conductors or fingers into case opening. Physical injury, shock or death may occur.
 G.2 Configured for either 110 volt or 220 volt AC operation; specify when ordering.



Distribution Centers NORTH AMERICA 800-654-7949 • 417 335-5935 • Fax 417-335-5945 • EUROPE 44-1252-832600 • Fax 44-1252-837010

INTERNET <http://www.minicircuits.com>

ISO 9001 CERTIFIED

Self-Cooled

VERY HIGH POWER 50W, 20 to 1000MHz



LZY-X*



LZY

up to 50W (+47 dBm) output

MODEL NO.	FREQ. (MHz) f_L-f_U	GAIN (dB)		POWER (dBm)			DYNAMIC RANGE		VSWR		DC POWER		CASE STYLE Note B	N O T C O M P O S I T I O N	PRICE \$ Qty. (1-9)
		Min.	Flatness Max.	Min. Output (1 dB Comp.)	Max. Output Typ.	Max. Input (no damage)	NF (dB) Typ.	IP3 (dBm) Typ.	In	Out	Volt (V)	Max. Current** (A)			
LZY-1	20 - 512	39	±1.5	+44	+47	+10	8.6*	54	2.0:1	*	+26	7.3	BT412	—	1995.00
LZY-2	500 -1000	40	±1.5	+43	+45	+10	8.0	54	2.0:1	3.5:1	+28	8.0	BT451	—	2195.00

* To order without heat sink and fan, add suffix -X to model number.
Alternative heat sinking and heat removal must be provided by customer to ensure proper performance. See application note AN-60-004 for LZY-1, AN-60-005 for LZY-2. Deduct \$100 from price list.

features

- saturated power 50W typ. (LZY-1) and 32W typ. (LZY-2)
- high power with low distortion, -32 dBc typ. (LZY-1) and -45 dBc typ. (LZY-2) harmonics at 20 watts
- wide bandwidth, usable 10 - 525 MHz and 475 - 1050 MHz
- high gain, 42 dB typ. (LZY-1) and 47 dB typ. (LZY-2)
- unconditionally stable
- self protected against excessive drive, high case temp., reverse polarity and shorting/unshorting transients at dc input
- electronic shutoff by grounding the shut-off terminal, reduces output by 50 dB. Open circuiting terminal restores full power within 100 μ sec.
- cool operation with integral fan, 15° C typ. rise
- graceful degradation, +20 to +30V DC
- can withstand short and open circuit at output for 2 minutes while delivering 20 watts

NOTES:

- * 80-512 MHz, at 20 MHz 11.6 dB typ.
- ** At 25W output for LZY-1 and 20W for LZY-2; includes fan
- B. Connector types and case mounted options, case finishes are given in section 0, see "Case styles & Outline Drawings".
- C. Prices and Specifications subject to change without notice.
- D. For Quality Control Procedures see Table of Contents, Section 0, "Mini-Circuits Guarantees Quality" article. For environmental Specifications see Amplifier Selection Guide.
- 1. Absolute max. dc voltage: +30V
- 2. Operating air-ambient temp. for specified performance: -10°C to 50°C
- 3. Max. storage temp.: -55°C to 100°C
- ⚡ VSWR 9:1 typ. up to 450 MHz, all specifications for 50 ohm load.